

stepper motor

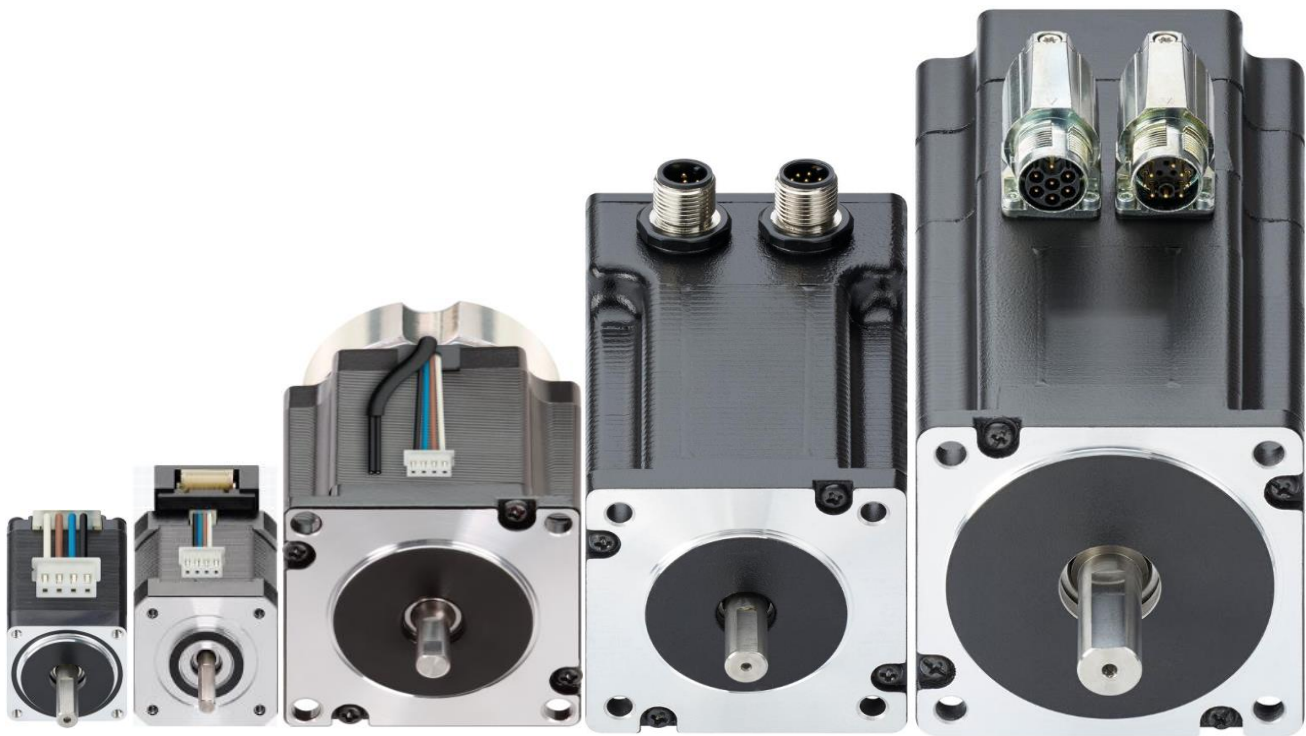

- 2-phase hybrid stepper motor (bipolar)
- high protection class
- with plug or stranded wires
- optional with encoder / brake

stepper motor MOT-AN-S . . .

part number (not configurable, only for illustration)

MOT – AN – S – 060 – 020 – 056 – M – A – AAAA

specifics	
AAAA	standard
AAAC	incremental encoder
AAAD	incremental encoder & brake
AAAO	short size
AAAS	incremental encoder & IP65

options	
A	without
B	brake
C	encoder
D	encoder and brake

motor connection	
M	metric plug
L	stranded wire

flange dimension	
028	28mm (NEMA11)
042	42mm (NEMA17)
056	56mm (NEMA23)
060	60mm (NEMA24)
086	86mm (NEMA34)

holding torque	
001	0,1Nm
002	0,2Nm
005	0,5Nm
010	1,0Nm
017	1,7Nm
020	2,0Nm
035	3,5Nm
036	3,6Nm
059	5,9Nm

max voltage	
060	60VDC

motor type	
S	stepper motor

type	
AN	version

product group	
MOT	motor

technical data						
flange dimension		28(NEMA11)	42(NEMA17)	56(NEMA23)	60(NEMA24)	86(NEMA34)
motor						
max voltage	[VDC]	60	60	60	60	60
nominal voltage	[VDC]	24-48	24-48	24-48	24-48	24-48
nominal current	[A]	1,0	1,8	4,2	4,2	6,4
holding torque	[Nm]	0,12	0,5	2,0	3,5	5,9
detent torque	[Nm]	0,004	0,022	0,068	0,075	0,210
step angle	[°]	1,8 ±5%	1,8 ±5%	1,8 ±5%	1,8 ±5%	1,8 ±5%
resistance / phase	[Ω]	2,30 ±10%	1,75 ±10%	0,50 ±10%	0,65 ±10%	0,33 ±10%
inductance / phase	[mH]	1,80 ±20%	3,30 ±20%	2,20 ±20%	3,20 ±20%	3,00 ±20%
dielectric strength	[VAC]	500	500	500	500	500
moment of inertia / rotor	[kgcm ²]	0,018	0,082	0,48	0,84	2,70
max. shaft load axial	[N]	7	7	15	15	65
max. shaft load radial	[N]	20	20	52	63	200

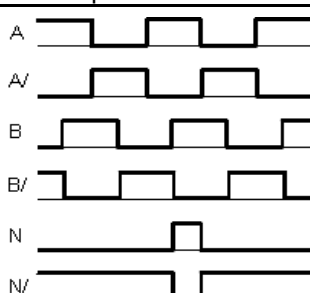
encoder (incremental)		
operating voltage	[VDC]	5
impulse / turn		500
zero impulse / index		yes
line-driver		RS422 protocol
signal sequence (motor rotation clockwise)	CW	

brake						
operating voltage	[VDC]	-	24 ±10%	24 ±10%	24 ±10%	24 ±10%
wattage	[W]	-	8	10	10	11
holding torque (metric connector)	[Nm]	-	0,4	1,0	1,0	2,0
holding torque (stranded wire)	[Nm]	-	0,5	1,0	1,0	2,0
backlash (stranded wire)	[°]	-	±1.5	±1.5	±1.5	±1.5
A brake-grinding-process is necessary for the initial start-up or if the brake was inactive for a long time.		Let the motor run at 200 rpm with the brake open, then apply the brake five times for 0.5 s.				
moment of inertia	[kgcm ²]	-	0,01	0,02	0,02	0,07
operating condition		The brake may closed not till then the motor idleness.				

weight						
stranded wires (JST)	[kg]	0,20	0,38	1,04	1,45	2,90
plug (M12)	[kg]	0,22	0,43	1,12	1,56	3,20
encoder (JST)	[kg]	0,27	0,40	1,05	1,35	2,95
encoder (M12)	[kg]	-	0,45	1,14	1,58	3,30
stranded wires (JST) and brake	[kg]	-	0,50	1,30	1,70	3,30
encoder and brake	[kg]	-	0,58	1,36	1,82	3,60

operating data		
ambient temperature	[°C]	-10 ... +50
max temperature rise	[°C]	80
insulation class	[°C]	B 130
humidity (not condensing)	[%]	85
protection class engine case		IP65 shaft sealing, IP65 (shaft seal IP52), stranded wires IP40
CE		EMC guideline

stepper motor MOT-AN-S-...-AAAO

technical data						
flange dimension		28(NEMA11)	42(NEMA17)	56(NEMA23)	60(NEMA24)	86(NEMA34)
motor						
max voltage	[VDC]	60	60	60	60	60
nominal voltage	[VDC]	24-48	24-48	24-48	24-48	24-48
nominal current	[A]	0,7	1,4	2,8	4,3	6,4
holding torque	[Nm]	0,061	0,2	1,0	1,7	3,6
detent torque	[Nm]	0,003	0,012	0,03	0,05	0,15
step angle	[°]	1,8 ±5%	1,8 ±5%	1,8 ±5%	1,8 ±5%	1,8 ±5%
resistance / phase	[Ω]	5,6 ±10%	1,7 ±10%	0,7 ±10%	0,45 ±10%	0,3 ±10%
inductance / phase	[mH]	4,0 ±20%	2,0 ±20%	2,0 ±20%	1,4 ±20%	1,9 ±20%
dielectric strength	[VAC]	500	500	500	500	500
moment of inertia / rotor	[kgcm ²]	0,009	0,038	0,230	0,350	0,850
max. shaft load axial	[N]	15	25	40	40	65
max. shaft load radial	[N]	30	30	70	70	220

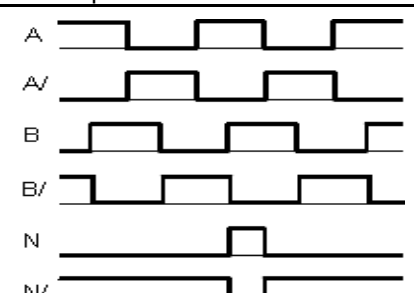
encoder (incremental)	
operating voltage	[VDC] 5
impulse / turn	500
zero impulse / index	yes
line-driver	RS422 protocol
signal sequence (motor rotation clockwise)	CW 

weight						
stranded wires (JST)	[kg]	0,11	0,17	0,61	0,75	1,80
stranded wires (JST) and encoder	[kg]	0,125	0,18	0,63	0,80	1,85

operating data	
ambient temperature	[°C] -10 ... +50
max temperature rise	[°C] 80
insulation class	[°C] B 130
humidity (not condensing)	[%] 85
protection class engine case	IP65 shaft sealing, IP65 (shaft seal IP52), stranded wires IP40
CE	EMC guideline

stepper motor MOT-AN-S . . .

pin assignment wire motor flange dimension 28,42,56,60(NEMA11,17,23,24) **pin assignment wire motor** flange dimension 86(NEMA34)

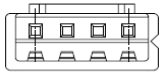

4 1

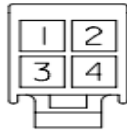

motor bipolar		motor wires	
JST XHP-4		wires*/ cable	
pin	signal	coil	color
1	A	1	white
2	A/		brown
3	B	2	blue
4	B/		black

* wire length 250mm

Motor bipolar		motor wires	
Molex 469920410		wires*	
pin	signal	coil	color
1	A	1	white
2	A/		brown
3	B	2	blue
4	B/		black

* wire length 300mm

pin assignment M12 motor flange dimension 28,42,56,60(NEMA11,17,23,24) **pin assignment M17 motor (swivels ± 90°)** flange dimension 86(NEMA34)

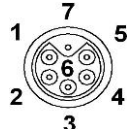
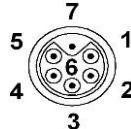
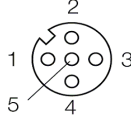
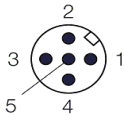

motor bipolar		motor cable	
M12 5-pole		M12 5-pole	
pin	signal	coil	color
1	A/	1	brown
2	A		white
3	B	2	blue
4	B/		black
5	PE		green/yellow
housing	shielding		-

motor bipolar		motor cable	
M17 7-pole		M17 7-pole	
pin	signal	coil	number
1	A/	1	1
2	A		2
3	B	2	3
4	B/		4
5	brake 24V		5
6	brake 0V		6
7	PE		green/yellow
housing	shielding		shielding

pin assignmen brake flange dimension 42,56,60(NEMA17,23,24) **pin assignmen wire brake (swivels ± 90°)** flange dimension 42,56,60,86(NEMA17,23,24,34)

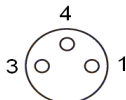

brake		brake cable	
M8 3-pole		M8 3-pole	
pin	signal	color	
1	brake (24V)	brown	
3	0V	blue	
4	-	black	

brake		
wire 2-pole		
pin	signal	color
-	brake	black
-	brake	black

* 24V (Polarity does not have to be taken into account)

stepper motor MOT-AN-S . . .

pin assignment wire encoder flange dimension 28(NEMA11) **pin assignment wire encoder** flange dimension 42,56,60,86(NEMA17,23,24,34)

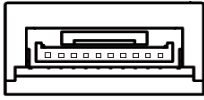

1

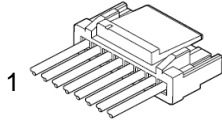

1

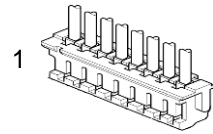

1

encoder connector		encoder cable
JST / SM10B-GHS-TB		JST / GHR-10V-S
pin	signal	color
1	shielding	shielding
2	A	white
3	A/	brown
4	B/	green
5	B	yellow
6	N/	grey
7	N	pink
8	0V	blue
9	5V DC	red
10	shielding	shielding

encoder connector		encoder cable
JST / B8B-ZR-SM4-TF		JST / ZHR-8
pin	signal	color
1	0V	blue
2	5V DC	red
3	A	white
4	A/	brown
5	B/	green
6	B	yellow
7	N/	grey
8	N	pink

pin assignment M12 encoder flange dimension 42,56,60(NEMA17,23,24) **pin assignment M17 encoder (swivels ± 90°)** flange dimension 86(NEMA34)

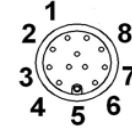
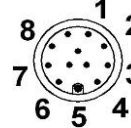
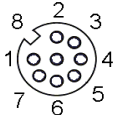
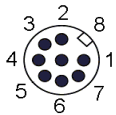

encoder		encoder cable
M12 8-pole		M12 8-pole
pin	signal	color
1	A	white
2	A/	brown
3	B	green
4	B/	yellow
5	0V	grey
6	N/	pink
7	N	blue
8	5V DC	red
housing	shielding	shielding

encoder		encoder cable
M17 12-pole		M17 12-pole
pin	signal	color
1	A	brown
2	A/	green
3	B	blue
4	B/	violet
5	0V	white 0,5 ²
6	N/	grey
7	N	pink
8	5V DC	brown 0,5 ²
9	-	-
10	-	-
11	-	-
12	-	-
housing	shielding	shielding

stepper motor MOT-AN-S-...-AAAA/C/D/S

characteristic flange dimension 28 (NEMA11) MOT-AN-S-060-001-028-...	flange dimension 42 (NEMA17) MOT-AN-S-060-005-042-...
--	---

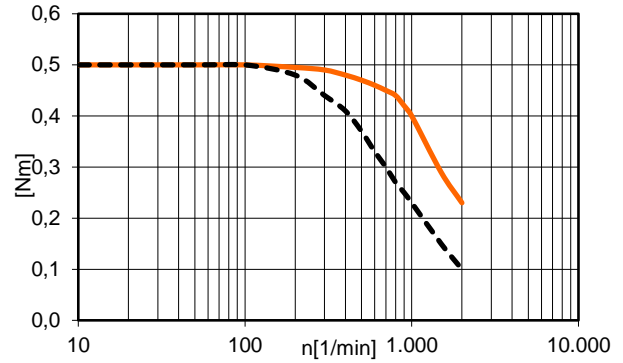
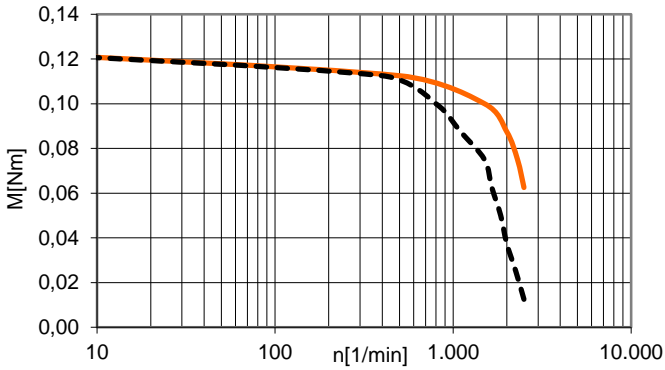

flange dimension 56 (NEMA23) MOT-AN-S-060-020-056-...	flange dimension 60 (NEMA24) MOT-AN-S-060-035-060-...
---	---

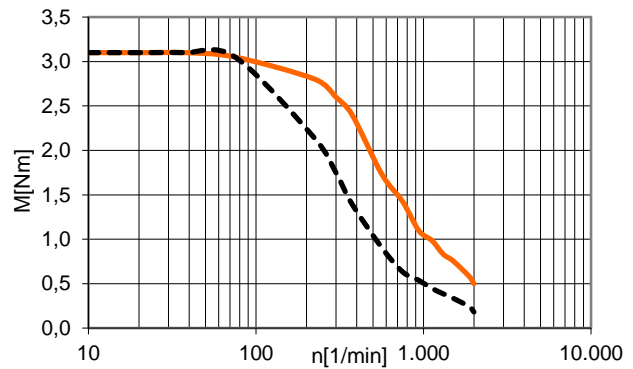
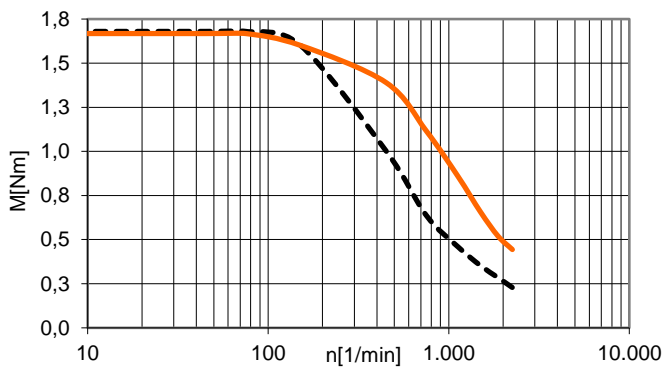

flange dimension 86 (NEMA34) MOT-AN-S-060-059-086-...

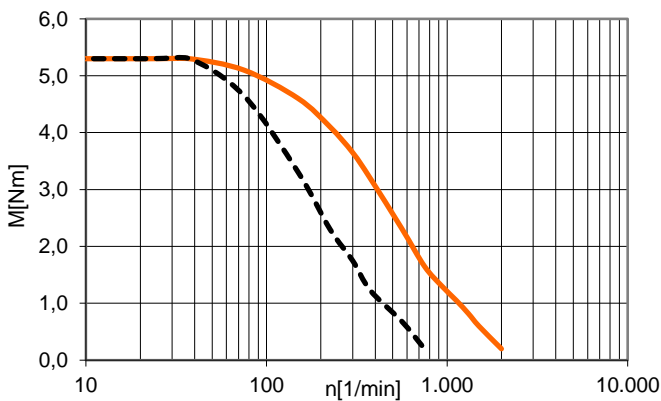

- - - - 24VDC — 48 VDC characteristic based on quarter step mode

stepper motor MOT-AN-S-...-AAAA/C/D/S

characteristic
flange dimension 28 (NEMA11) MOT-AN-S-060-001-028-...
flange dimension 42 (NEMA17) MOT-AN-S-060-002-042-...

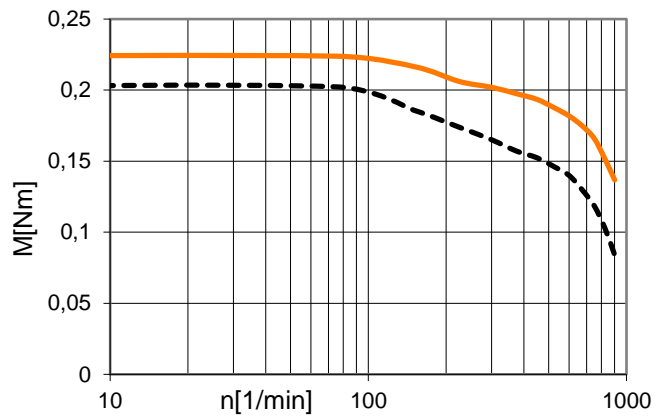
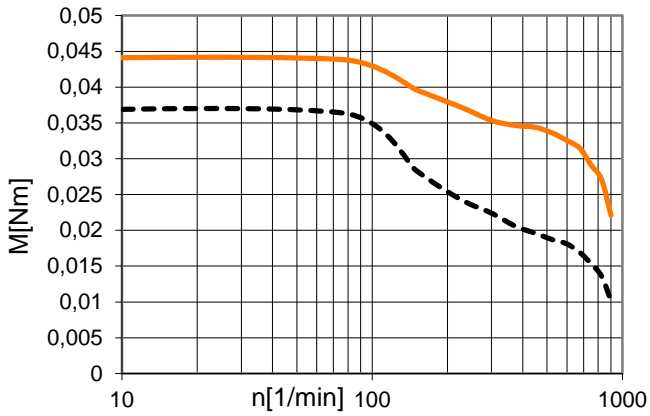

flange dimension 56 (NEMA23) MOT-AN-S-060-010-056-...
flange dimension 60 (NEMA24) MOT-AN-S-060-016-060-...

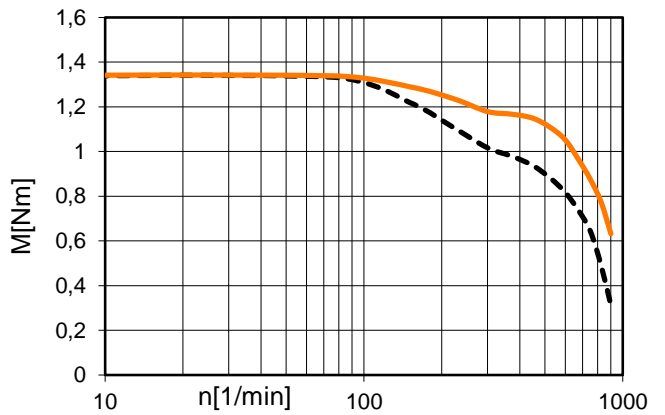
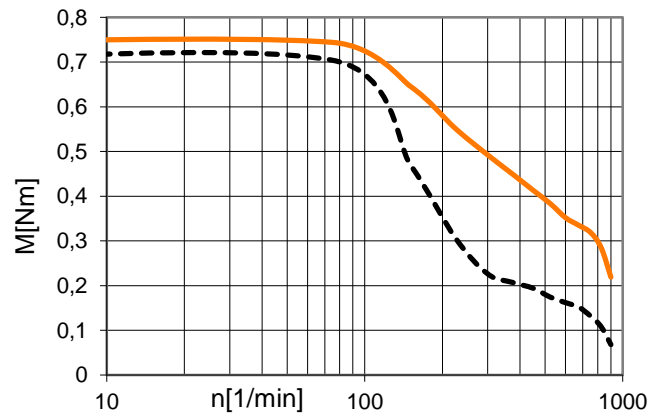

flange dimension 86 (NEMA34) MOT-AN-S-060-036-086-...

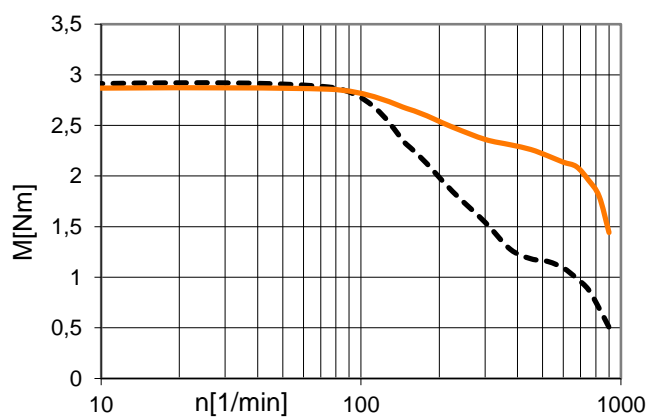

----- 24VDC ———— 48 VDC characteristic based on quarter step mode

stepper motor MOT-AN-S . . .

dimensions

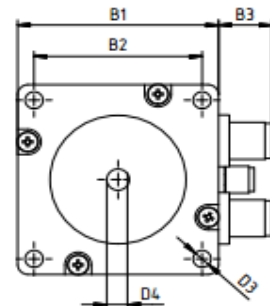

Typ	B1 [mm] ±0,2	B2 [mm] ±0,2	B3 [mm]	D1 Ø [mm] -0,013	D2 Ø [mm] ±0,025	D3 Ø [mm]	D4 [mm] ±0,15	L1 [mm] ±1	L2 [mm] ±1	L3 [mm]	L4 [mm]	L5 [mm] ±1
MOT-AN-S-060-001-028-L-A-AAAA	28,0	23,00	-	5,00	22,00	M2,5-3,5	4,5	20,0	50	2,0	-	15,0
MOT-AN-S-060-001-028-L-A-AAAO	28,0	23,00	-	5,00	22,00	M2,5-3,6	4,5	20,0	31,5	2,0	-	15,0
MOT-AN-S-060-001-028-L-C-AAAC	28,0	23,00	-	5,00	22,00	M2,5-3,7	4,5	20,0	60	2,0	-	15,0
MOT-AN-S-060-001-028-L-C-AAAO	28,0	23,00	-	5,00	22,00	M2,5-3,8	4,5	20,0	41,5	2,0	-	15,0
MOT-AN-S-060-001-028-M-A-AAAA	28,0	23,00	13	5,00	22,00	M2,5-3,5	4,5	20,0	70	2,0	-	15,0
MOT-AN-S-060-002-042-L-A-AAAO	42,3	31,00	-	5,00	22,00	M3-4,4	4,5	24,0	30,5	2,0	-	19,0
MOT-AN-S-060-005-042-L-A-AAAA	42,3	31,00	-	5,00	22,00	M3-4,5	4,5	24,0	49	2,0	-	19,0
MOT-AN-S-060-005-042-L-B-AAAA	42,3	31,00	-	5,00	22,00	M3-4,6	4,5	24,0	78	2,0	-	19,0
MOT-AN-S-060-002-042-L-C-AAAO	42,3	31,00	-	5,00	22,00	M3-4,7	4,5	24,0	46,2	2,0	-	19,0
MOT-AN-S-060-005-042-L-C-AAAC	42,3	31,00	-	5,00	22,00	M3-4,5	4,5	24,0	63	2,0	-	19,0
MOT-AN-S-060-005-042-M-A-AAAA	42,3	31,00	13	5,00	22,00	M3-4,5	4,5	24,0	70	2,0	-	19,0
MOT-AN-S-060-005-042-M-C-AAAC	42,3	31,00	13	5,00	22,00	M3-4,5	4,5	24,0	70	2,0	-	19,0
MOT-AN-S-060-005-042-M-C-AAAS	42,3	31,00	13	5,00	22,00	M3-4,5	4,5	24,0	73	2,0	-	19,0
MOT-AN-S-060-005-042-M-D-AAAD	42,3	31,00	13	5,00	22,00	M3-4,5	4,5	24,0	106,4	2,0	-	19,0
MOT-AN-S-060-010-056-L-A-AAAO	56,4	47,14	-	6,35	38,10	5,0	5,8	20,6	50	1,6	5	16,0
MOT-AN-S-060-010-056-L-C-AAAO	56,4	47,14	-	6,35	38,10	5,0	5,8	20,6	65,7	1,6	5	16,0
MOT-AN-S-060-016-060-L-A-AAAO	60,0	47,14	-	8,00	38,10	4,5	7,5	20,6	56	1,6	6	16,0
MOT-AN-S-060-016-060-L-C-AAAO	60,0	47,14	-	8,00	38,10	4,5	7,5	20,6	71,7	1,6	6	16,0
MOT-AN-S-060-020-056-L-A-AAAA	56,4	47,14	-	6,35	38,10	5,0	5,8	20,6	76	1,6	5	16,0
MOT-AN-S-060-020-056-L-B-AAAA	56,4	47,14	-	6,35	38,10	5,0	5,8	20,6	105	1,6	5	16,0
MOT-AN-S-060-020-056-L-C-AAAC	56,4	47,14	-	6,35	38,10	5,0	5,8	20,6	91	1,6	5	16,0
MOT-AN-S-060-020-056-M-A-AAAA	56,4	47,14	13	6,35	38,10	5,0	5,8	20,6	98	1,6	5	16,0
MOT-AN-S-060-020-056-M-C-AAAC	56,4	47,14	13	6,35	38,10	5,0	5,8	20,6	98	1,6	5	16,0
MOT-AN-S-060-020-056-M-C-AAAS	56,4	47,14	13	6,35	38,10	5,0	5,8	20,6	99	1,6	6	16,0
MOT-AN-S-060-020-056-M-D-AAAD	56,4	47,14	13	6,35	38,10	5,0	5,8	20,6	138	1,6	5	16,0
MOT-AN-S-060-035-060-L-A-AAAA	60,0	47,14	9	8,00	38,10	4,5	7,5	20,6	88	1,6	7	16,0
MOT-AN-S-060-035-060-L-B-AAAA	60,0	47,14	9	8,00	38,10	4,5	7,5	20,6	118	1,6	7	16,0
MOT-AN-S-060-035-060-L-C-AAAC	60,0	47,14	9	8,00	38,10	4,5	7,5	20,6	105	1,6	7	16,0
MOT-AN-S-060-035-060-M-A-AAAA	60,0	47,14	13	8,00	38,10	4,5	7,5	20,6	112	1,6	7	16,0
MOT-AN-S-060-035-060-M-C-AAAC	60,0	47,14	13	8,00	38,10	4,5	7,5	20,6	112	1,6	7	16,0
MOT-AN-S-060-035-060-M-C-AAAS	60,0	47,14	13	8,00	38,10	4,5	7,5	20,6	112	1,6	7	16,0
MOT-AN-S-060-035-060-M-D-AAAD	60,0	47,14	13	8,00	38,10	4,5	7,5	20,6	150	1,6	7	16,0

stepper motor MOT-AN-S . . .

dimensions

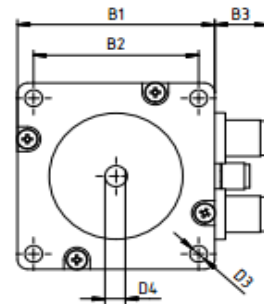
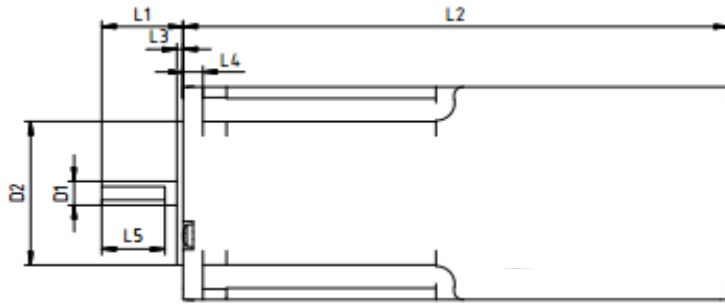

Typ	B1 [mm] ±0,2	B2 [mm] ±0,2	B3 [mm]	D1 Ø [mm] -0,013	D2 Ø [mm] ±0,025	D3 Ø [mm]	D4 [mm] ±0,15	L1 [mm] ±1	L2 [mm] ±1	L3 [mm]	L4 [mm]	L5 [mm] ±1
MOT-AN-S-060-036-086-L-A-AAAO	85,8	69,50	-	14,00	73,02	6,6	13,0	37,0	66	2,0	10	32,0
MOT-AN-S-060-036-086-L-C-AAAO	85,8	69,50	-	14,00	73,02	6,6	13,0	37,0	81,7	2,0	10	32,0
MOT-AN-S-060-059-086-L-A-AAAA	85,8	69,50	-	14,00	73,02	6,6	13,0	37,0	98	2,0	10	32,0
MOT-AN-S-060-059-086-L-B-AAAA	85,8	69,50	-	14,00	73,02	6,6	13,0	37,0	130	2,0	10	32,0
MOT-AN-S-060-059-086-L-C-AAAC	85,8	69,50	-	14,00	73,02	6,6	13,0	37,0	113	2,0	10	32,0
MOT-AN-S-060-059-086-M-A-AAAA	85,8	69,50	37	14,00	73,02	6,6	13,0	37,0	118	2,0	8	32,0
MOT-AN-S-060-059-086-M-C-AAAC	85,8	69,50	37	14,00	73,02	6,6	13,0	37,0	118	2,0	8	32,0
MOT-AN-S-060-059-086-M-D-AAAD	85,8	69,50	37	14,00	73,02	6,6	13,0	37,0	188	2,0	8	32,0

stepper motor MOT-AN-S . . .

connecting cable				
part number	outer jacket	type	cable length	plug
flange dimension 28(NEMA11), 42(NEMA17), 56(NEMA23), 60(NEMA24)				
motor cable Ø: 5,5 mm / bending radius moved < 10m travel distance: min. 5 x d				
DLE904121451-3 (MAT9043737 old)	TPE	CF9.03.05.INI	3	straight
DLE904121451-5 (MAT9043738 old)	TPE	CF9.03.05.INI	5	straight
DLE904121451-10 (MAT9043740 old)	TPE	CF9.03.05.INI	10	straight
DLE904121452-3 (MAT9043742 old)	TPE	CF9.03.05.INI	3	angulate
DLE904121452-5 (MAT9043743 old)	TPE	CF9.03.05.INI	5	angulate
DLE904121452-10 (MAT9043745 old)	TPE	CF9.03.05.INI	10	angulate
encoder cable Ø: 7 mm / bending radius moved < 10m travel distance: min. 10 x d				
DLE904121455-3 (MAT90432594-3 old)	PVC	CF240.02.08	3	straight
DLE904121455-5 (MAT90432594-5 old)	PVC	CF240.02.08	5	straight
DLE904121455-10 (MAT90432594-10 old)	PVC	CF240.02.08	10	straight
DLE904121456-3 (MAT90436430-3 old)	PVC	CF240.02.08	3	angulate
DLE904121456-5 (MAT90436430-5 old)	PVC	CF240.02.08	5	angulate
DLE904121456-10 (MAT90436430-10 old)	PVC	CF240.02.08	10	angulate
flange dimension 86(NEMA34)				
motor cable Ø: 10,5 mm / bending radius moved < 10m travel distance: min. 6,8 x d				
DLE904121457-3 (MAT90439520-3 old)	PUR	CF78.UL.07.07	3	straight
DLE904121457-5 (MAT90439520-5 old)	PUR	CF78.UL.07.07	5	straight
DLE904121457-10 (MAT90439520-10 old)	PUR	CF78.UL.07.07	10	straight
encoder cable Ø: 8 mm / bending radius moved < 10m travel distance: min.. 10 x d				
DLE904121458-3 (MAT90439519-3 old)	PVC	CF211.009	3	straight
DLE904121458-5 (MAT90439519-5 old)	PVC	CF211.009	5	straight
DLE904121458-10 (MAT90439519-10 old)	PVC	CF211.009	10	straight
flange dimension 42(NEMA17), 56(NEMA23), 60(NEMA24)				
brake cable Ø: 4,5 mm / bending radius moved < 10m travel distance: min. 5 x d				
DLE904121453-3 (MAT9043716 old)	TPE	CF9.02.03.INI	3	straight
DLE904121453-5 (MAT9043717 old)	TPE	CF9.02.03.INI	5	straight
DLE904121453-10 (MAT9043719 old)	TPE	CF9.02.03.INI	10	straight
DLE904121454-3 (MAT9043724 old)	TPE	CF9.02.03.INI	3	angulate
DLE904121454-5 (MAT9043725 old)	TPE	CF9.02.03.INI	5	angulate
DLE904121454-10 (MAT9043727 old)	TPE	CF9.02.03.INI	10	angulate

cable wire motor				
part number	outer jacket	type	cable length	plug
flange dimension 28(NEMA11), 42(NEMA17), 56(NEMA23), 60(NEMA24)				
motor (extension)		cable Ø: 5,5 mm / bending radius moved < 10m travel distance: min. 5 x d		
DLE904121461-3 (MAT90490015-3 alt)	TPE	CF9.03.05.INI	3	straight
DLE904121461-5 (MAT90490015-5 alt)	TPE	CF9.03.05.INI	5	straight
DLE904121461-10 (MAT90490015-10 alt)	TPE	CF9.03.05.INI	10	straight
flange dimension 86(NEMA34)				
motor (extension)		cable Ø: 7 mm / bending radius moved < 10m travel distance: min. 5 x d		
DLE904161278-3 (MAT0172104-3 alt)	TPE	CF880.07.05	3	straight
DLE904161278-5 (MAT0172104-5 alt)	TPE	CF880.07.05	5	straight
DLE904161278-10 (MAT0172104-10 alt)	TPE	CF880.07.05	10	straight
encoder (also for 86(NEMA34))		cable Ø: 7,5 mm / bending radius moved < 10m travel distance: min. 6,8 x d		
DLE904121460-3 (MAT90476558-3 alt)	TPE	CF11.01.04.02	3	straight
DLE904121460-5 (MAT90476558-5 alt)	TPE	CF11.01.04.02	5	straight
DLE904121460-10 (MAT90476558-10 alt)	TPE	CF11.01.04.02	10	straight
encoder 28(NEMA11)		cable Ø: 7,5 mm / bending radius moved < 10m travel distance: min. 6,8 x d		
DLE904121459-3 (MAT90450903-3 alt)	TPE	CF11.01.04.02	3	straight
DLE904121459-5 (MAT90450903-5 alt)	TPE	CF11.01.04.02	5	straight
DLE904121459-10 (MAT90450903-10 alt)	TPE	CF11.01.04.04	10	straight

stepper motor MOT-AN-S . . .

component part

More Information about our comprehensive component parts can be found at our website

www.igus.eu

motor flange



spacer



coupling



initiator / initiator bracket

