

Motion Control Systems

V2.5, 4-Quadrant PWM with RS232 or CANopen interface

25 mNm
13 W

2250 ... BX4 CxD

Values at 22°C and nominal voltage	2250 S	012 BX4 CxD	024 BX4 CxD	
Power supply electronic	U_B/U_{EL}	8 ... 30	8 ... 30	V DC
Power supply motor ¹⁾	$-/U_B$	0 ... 30	0 ... 30	V DC
Nominal voltage for motor	U_N	12	24	V
No-load speed (at U_N)	n_0	5 500	5 700	min ⁻¹
Peak torque (S2 operation for max. 1s/2s)	M_{max}	44	50	mNm
Torque constant	k_M	19	36,9	mNm/A
PWM switching frequency	f_{PWM}	78	78	kHz
Efficiency electronic	η	95	95	%
Standby current for electronic (@ U_N)	I_{el}	0,04	0,04	A
Speed range (up to 24V / 30V)		1 ... 8 500	1 ... 7 500	min ⁻¹
Shaft bearings		ball bearings, preloaded		
Shaft load max.:				
– with shaft diameter	3			mm
– radial at 3 000 min ⁻¹ (5 mm from mounting flange)	20			N
– axial at 3 000 min ⁻¹ (push / pull)	2			N
– axial at standstill (push / pull)	20			N
Shaft play:				
– radial	≤ 0,015			mm
– axial	= 0			mm
Operating temperature range	-25 ... +85			°C
Housing material	stainless steel			
Mass	117			g

¹⁾ Only available for option 2993 (separate power supply)

Rated values for continuous operation				
Rated torque	M_N	22	25	mNm
Rated current (thermal limit)	I_N	1,38	0,77	A
Rated speed	n_N	3 900	4 500	min ⁻¹

Interface / range of functions	... CSD	... COD
Configuration from Motion Manager 5.0	RS232	CANopen
Fieldbus	RS232	CANopen
Operating modes (CSD)	Position/speed/torque control via interface or analogue set value specification. Operation as servo amplifier in voltage controller mode.	
Operating modes (COD)	Profile Position Mode (PP), Profile Velocity Mode (PV), Homing Mode, Cyclic Synchronous Position Mode (CSP)	
Speed range	see motor diagram	
Application programs, (CSD)	Command sequences from movement and control commands can be placed directly into the controller as user programs.	
Additional functions	Enables stand-alone operation without a connected communication interface. Overload protection for electronics and motor, self-protection from overheating, over-voltage protection in generator mode.	

Note:

The display shows the range of possible operation points of the drives at a given ambient temperature of 22°C.

The diagram indicates the recommended speed in relation to the available torque at the output shaft.

It includes the assembly on a plastic- as well as on a metal flange (assembly method: IM B 5).

The nominal voltage linear slope describes the maximal achievable operating points at nominal voltage. Any points of operation above this linear slope will require a supply voltage $U_{mot} > U_N$.

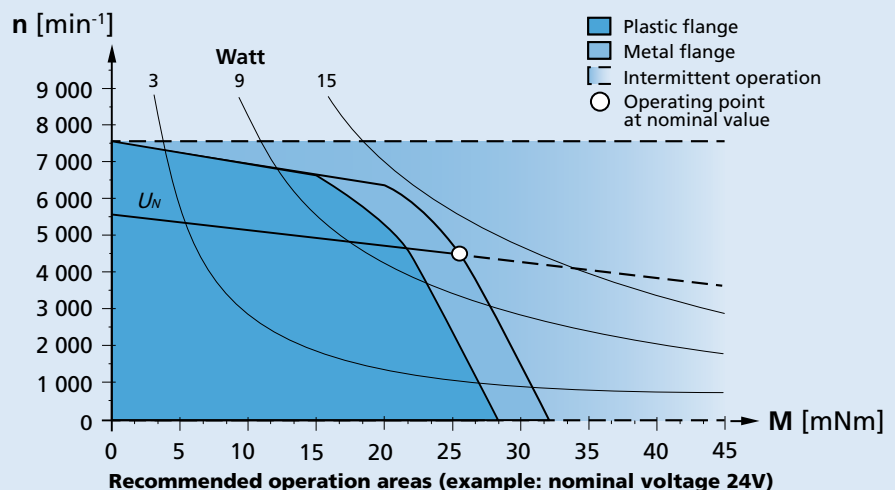

Dimensional drawing

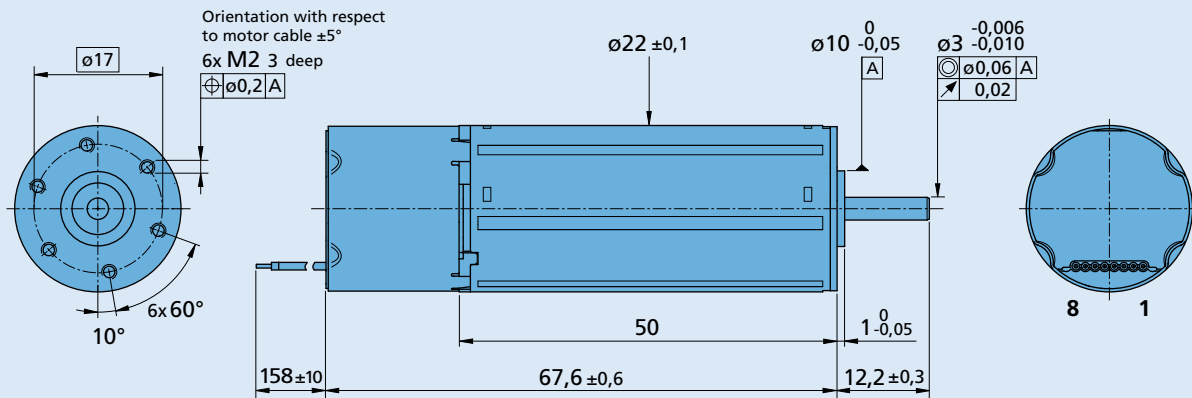

2250 ... BX4 CSD/COD

Option, cable and connection information

Example product designation: **2250S024BX4CSD-2993**

Option	Type	Description	Connection	
			No.	Function
3830	Connector 	AWG 26 / PVC ribbon cable with connector MOLEX Microfit 3.0, 43025-0800, recommended mating connector 43020-0800	1	Connection No. 3
2993	Supply	Separate voltage supply for motor and electronics	2	U_B
			3	GND
			4	Analog input
			5	Analog GND
			6	Fault output
			7	RS232 RXD / CAN_L
			8	RS232 TXD / CAN_H
			Standard cable PVC ribbon cable 8 x AWG 26, 1,27 mm	
			Note: For details on the connection assignment, see device manual MCS.	

Product combination

Precision Gearheads / Lead Screws	Encoders	Drive Electronics	Cables / Accessories
22GPT 22/7 26A 32GPT 22L ... ML 22L ... PB 22L ... SB 32L ... ML 32L ... PB 32L ... SB 32L ... TL		Integrated	To view our large range of accessory parts, please refer to the "Accessories" chapter.