

4611110012582

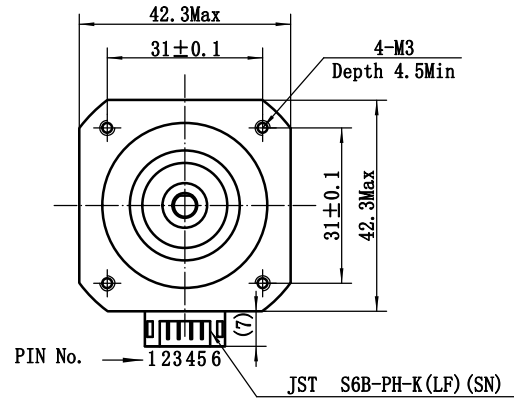

接线图  
Wiring Diagram

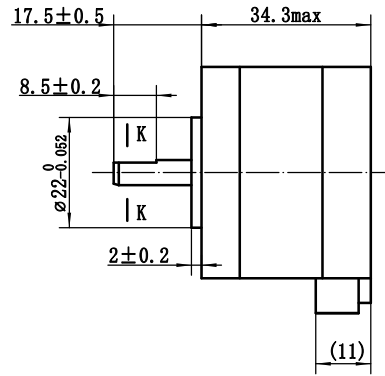
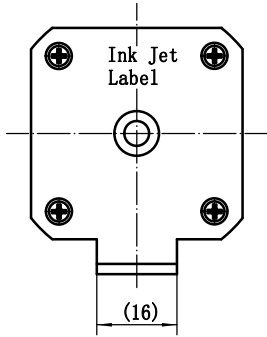
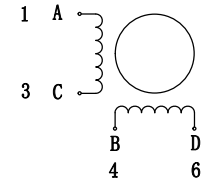

励磁顺序 vs. 旋转方向  
Exciting Sequence vs. Direction of Rotation

STEP	A	B	C	D	CW
1	+	+	-	-	↑
2	-	+	+	-	
3	-	-	+	+	
4	+	-	-	+	

从安装面看为顺时针方向  
Clockwise view from mounting side

规格 Specifications

1. 相数 Number of Phase	2
2. 步距角 Step Angle	1.8°
3. 额定电压 Rated Voltage	5.655 V DC
4. 额定电流 Rated Current	0.65 Amp
5. 保持力矩 Holding Torque	0.28N.m MIN(Two phase on/rated current)
6. 相电阻 Phase Resistance	8.7 ohm±10%(20° C)
7. 相电感 Phase Inductance	16.5 mH±20%(1kHz 1V rms)
8. 转子惯量 Rotor Inertia	38g.cm <sup>2</sup>
9. 电机重量 Motor Weight	0.21kg
10. 绝缘等级 Insulation Class	B(130° C)

铭牌 Label Detail

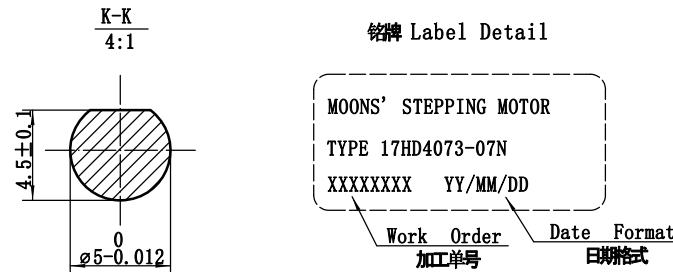

		Unit: mm 第一角画法 FIRST ANGLE METHOD		批准 Approve		MOONS' Hybrid Stepping Motor				
		未注线性与角度尺寸公差 Tolerances for linear and angular dimensions without individual tolerance indications GB/T 1804-m eqv ISO 2768-1Dm		标准化 Standard				Shanghai Moons' Electric Co., Ltd.		
		未注孔与槽尺寸公差 Geometrical tolerance for features without individual tolerance indications GB/T 1184-K eqv ISO 2768-2Dk		工艺 Technology		This document is released for information only. Its reproduction in whole or in part or its dissemination to third parties is prohibited. All trademarks and registered trademarks appearing on this document are the property of their respective owners.				
A 原始版本 Original revision		2014.04.15		审核 Check						
REV.	版本记录 REVISION RECORD	DATE	UNLESS OTHERWISE SPECIFIED	NAMES	SIGNATURE	DATE	Type: 17HD4073-07N	Rev. A	SCALE 1:1	Sheet 1 of 1