

Nema 17 Stepper Motor

Rev: A

Date:

COMMON RATINGS

Step angle :	0.9°	Dielectric strength :	500VAC
Positional accuracy :	±5%	Insulation resistance :	100Mohm(500VDC)
Number of Phase :	2	Ambient Temperature :	-10°C~50°C
Temperature rise :	80°C MAX	Insulation class :	B
Rotor Inertia :	54gcm ²	Weight :	0.28Kg

SPECIFICATIONS

Holding Torque (2 phases on) Kg.cm	Rated Current/Phase (Amps DC)	Phase Resistance (ohms) ±10%	Voltage Current/Phase (V DC)	Phase Inductance (mH)±20%(1KHz) Typical
3.6	0.9	6.0	5.4	12.0

DIMENSIONS unit=mm

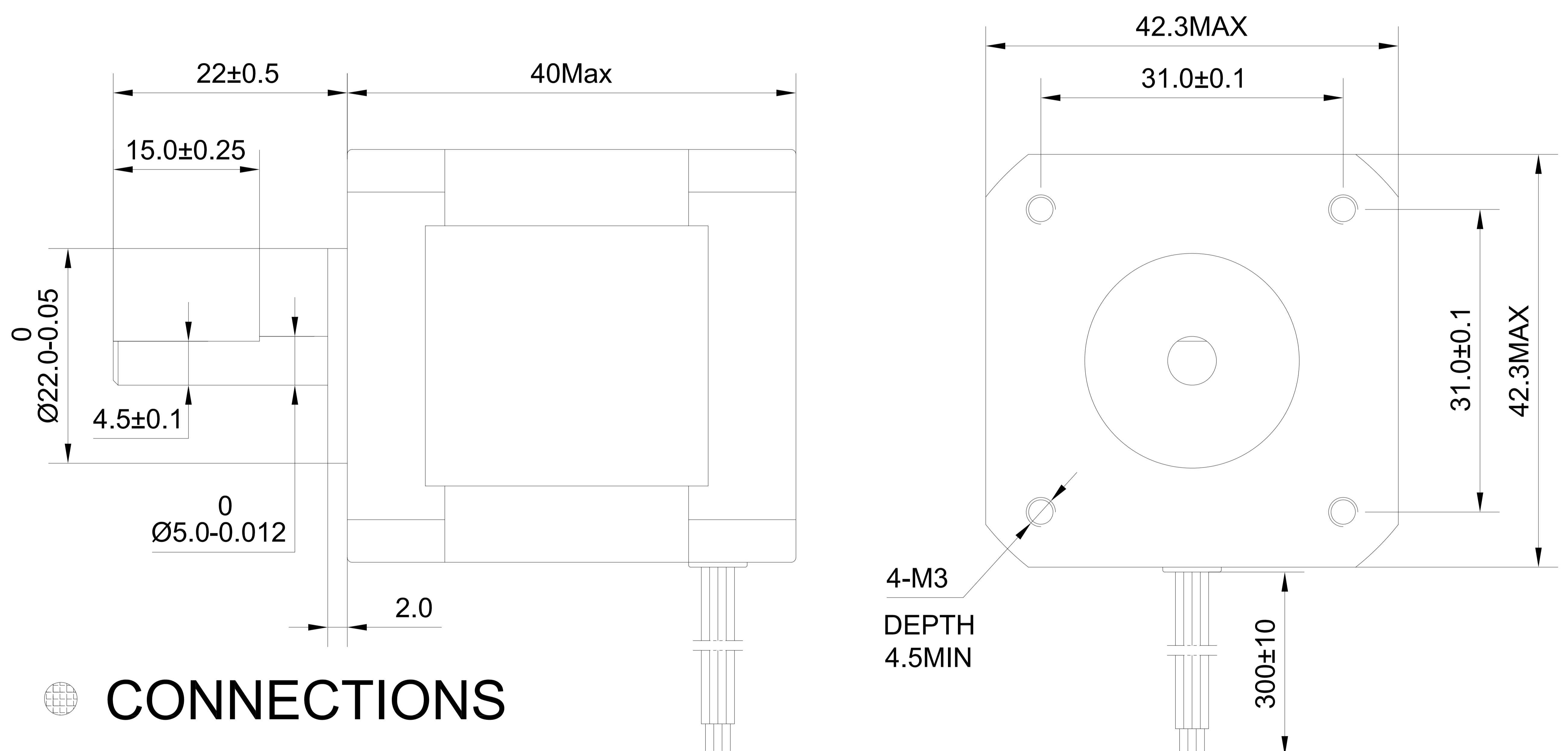

CONNECTIONS

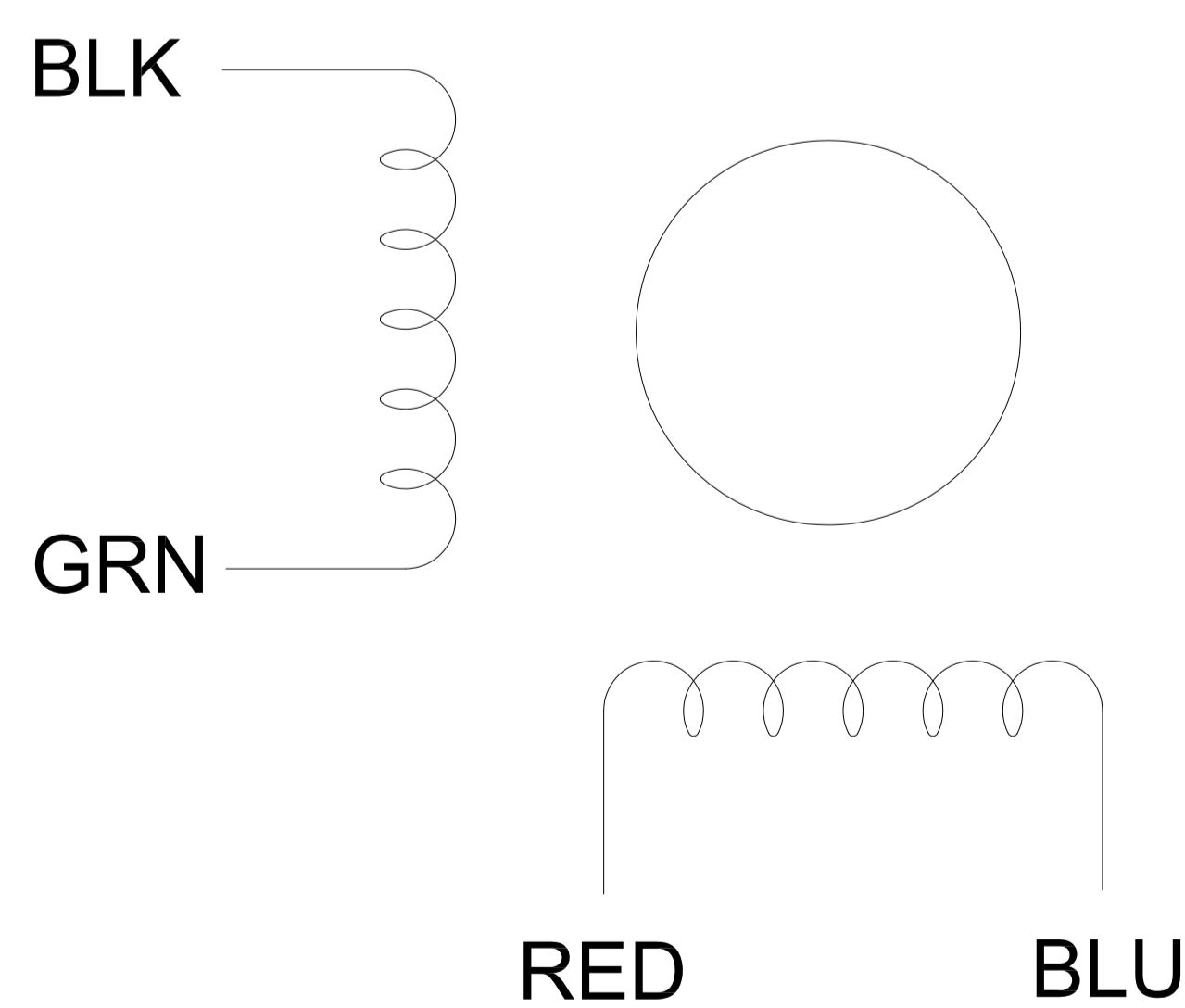

						17HM15-0904S			技术规格书		
标记	处数	分区	更改文件号	签名	日期						
设计			标准化			阶段标记	重量	比例			
审核									www.OMC-StepperOnline.com		
工艺			批准			共 张	第 张				