

# Duet3 Mainboard

Sheet: Processor

Processor

File: Processor.sch  
Sheet: sheet5F4EC370

IO

File: Endstops.sch  
Sheet: Power

Power

File: Power.sch

Sheet: Stepper Driver & Endstops

Stepper Drivers

File: Stepper\_Drv.sch  
Sheet: MOSFET outputs

MOSFET outputs

File: Htr\_Fan.sch

Sheet: Headers

Headers

File: Headers.sch  
Sheet: sheet5B64A4E5

Comms

File: Comms.sch

(c) Duet3D  
**Duet3d**

Sheet: /  
File: Duet3\_MB.sch

**Title: Duet 3 Main Board**

Size: A4 Date: 2019-10-05

KiCad E.D.A. kicad (5.1.4)-1

Rev: 1.0

Id: 1/8

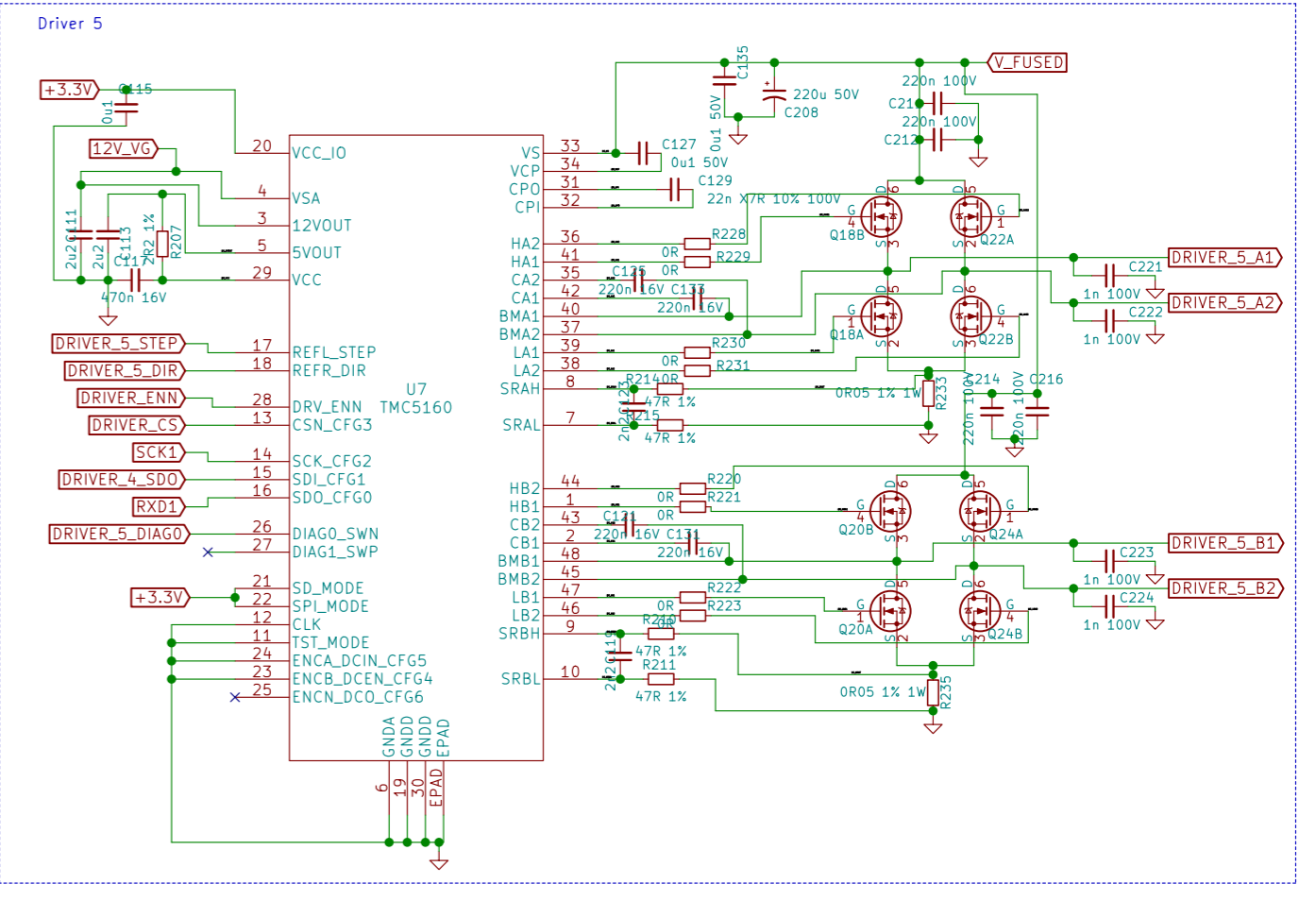
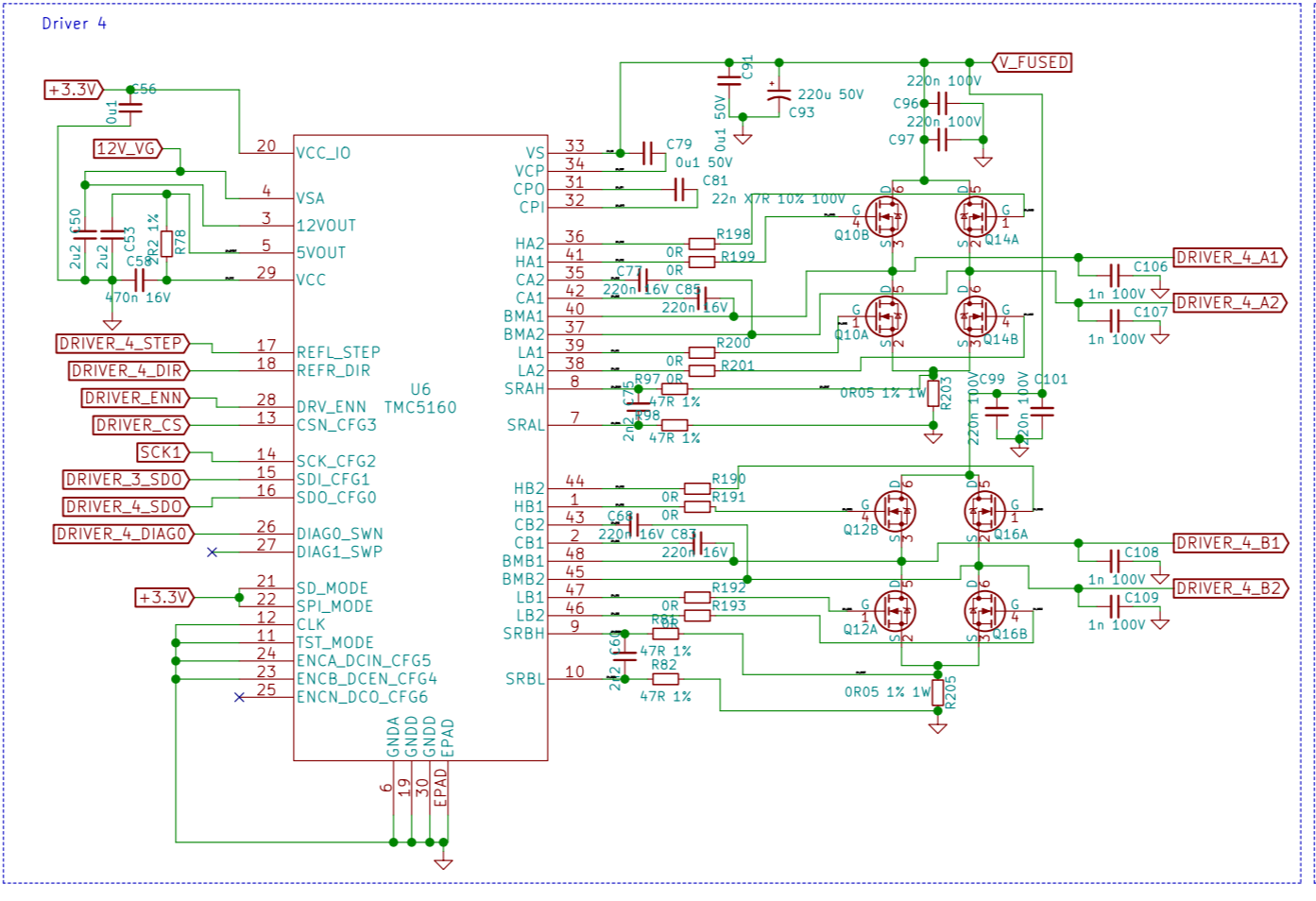
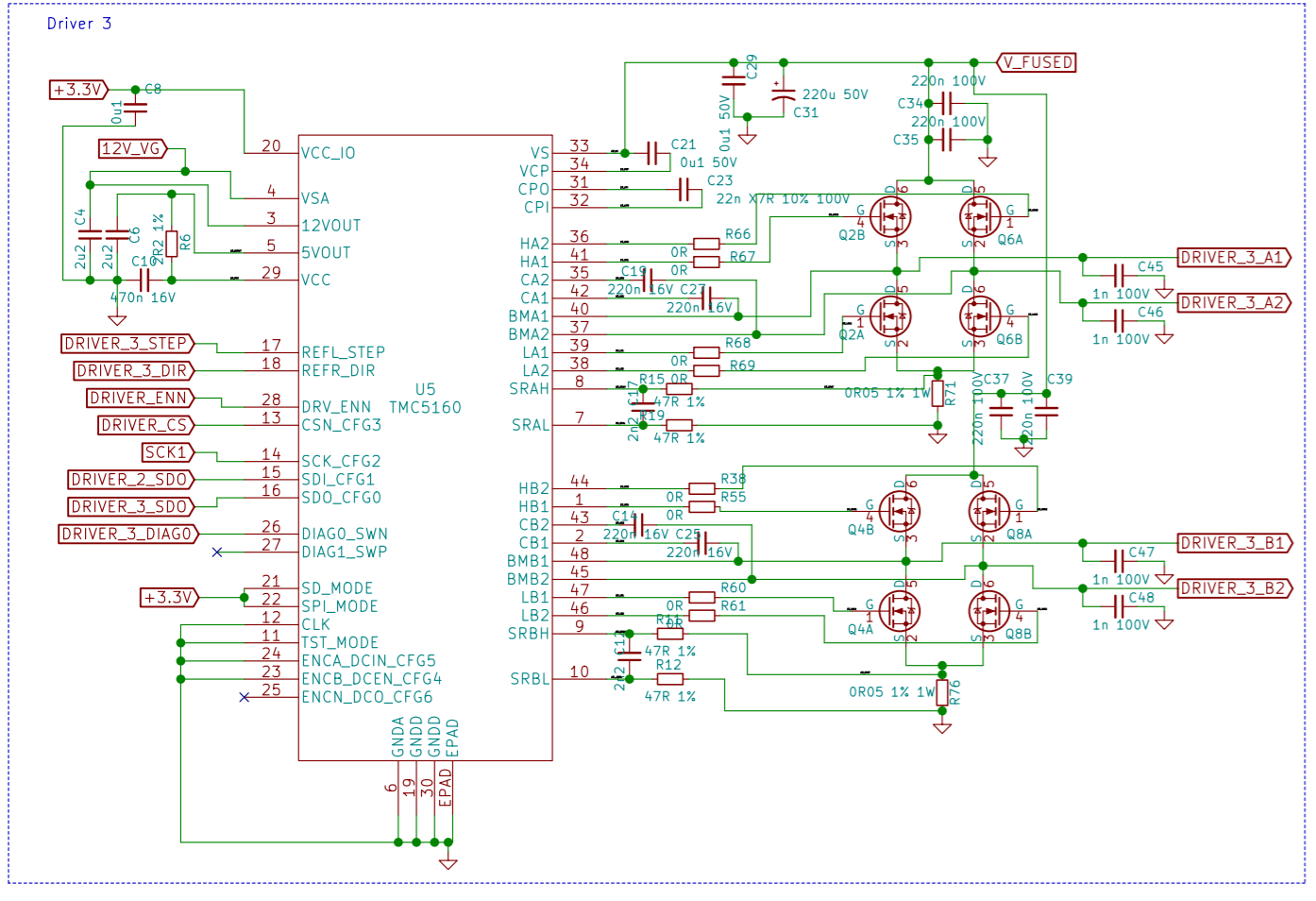
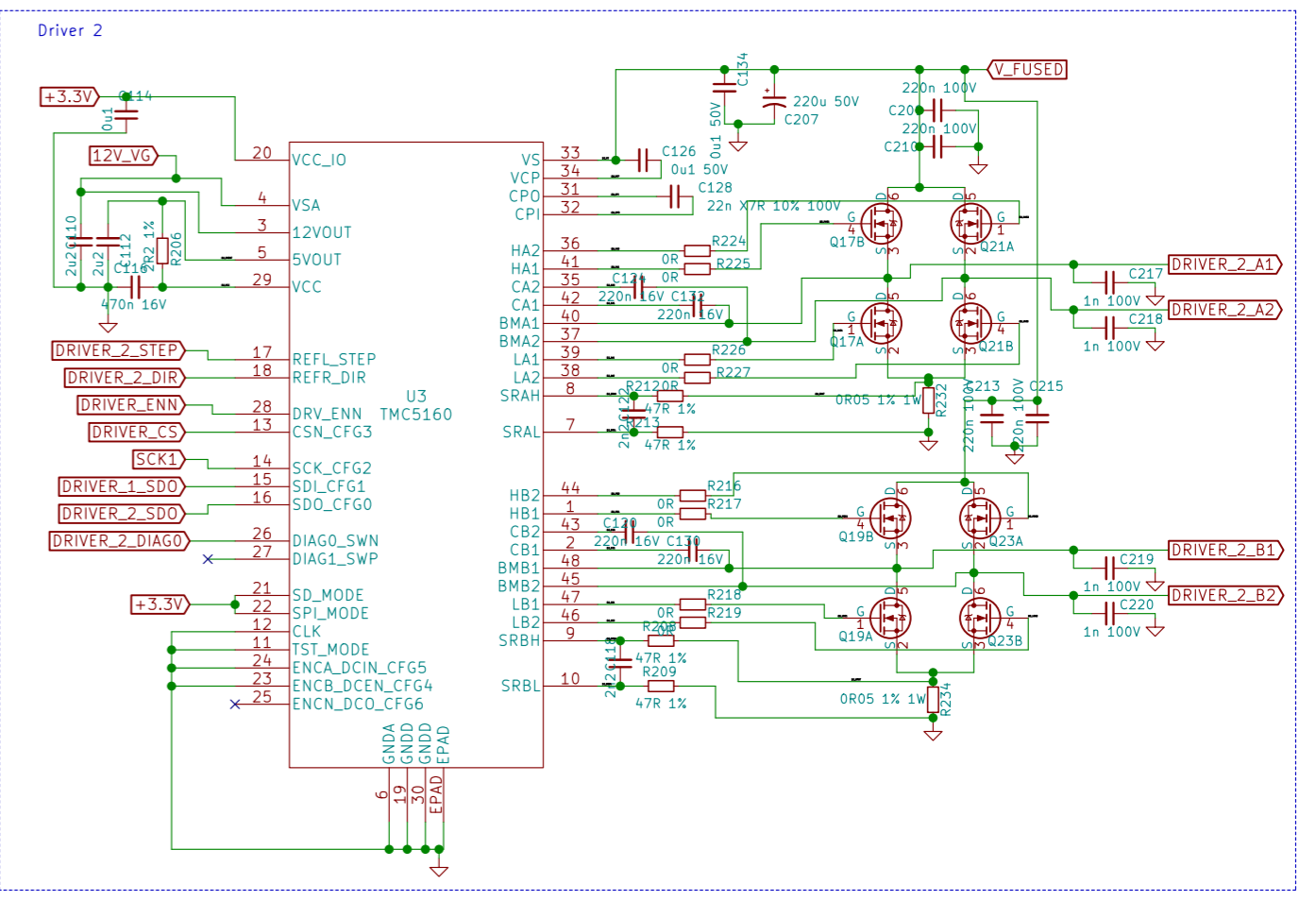
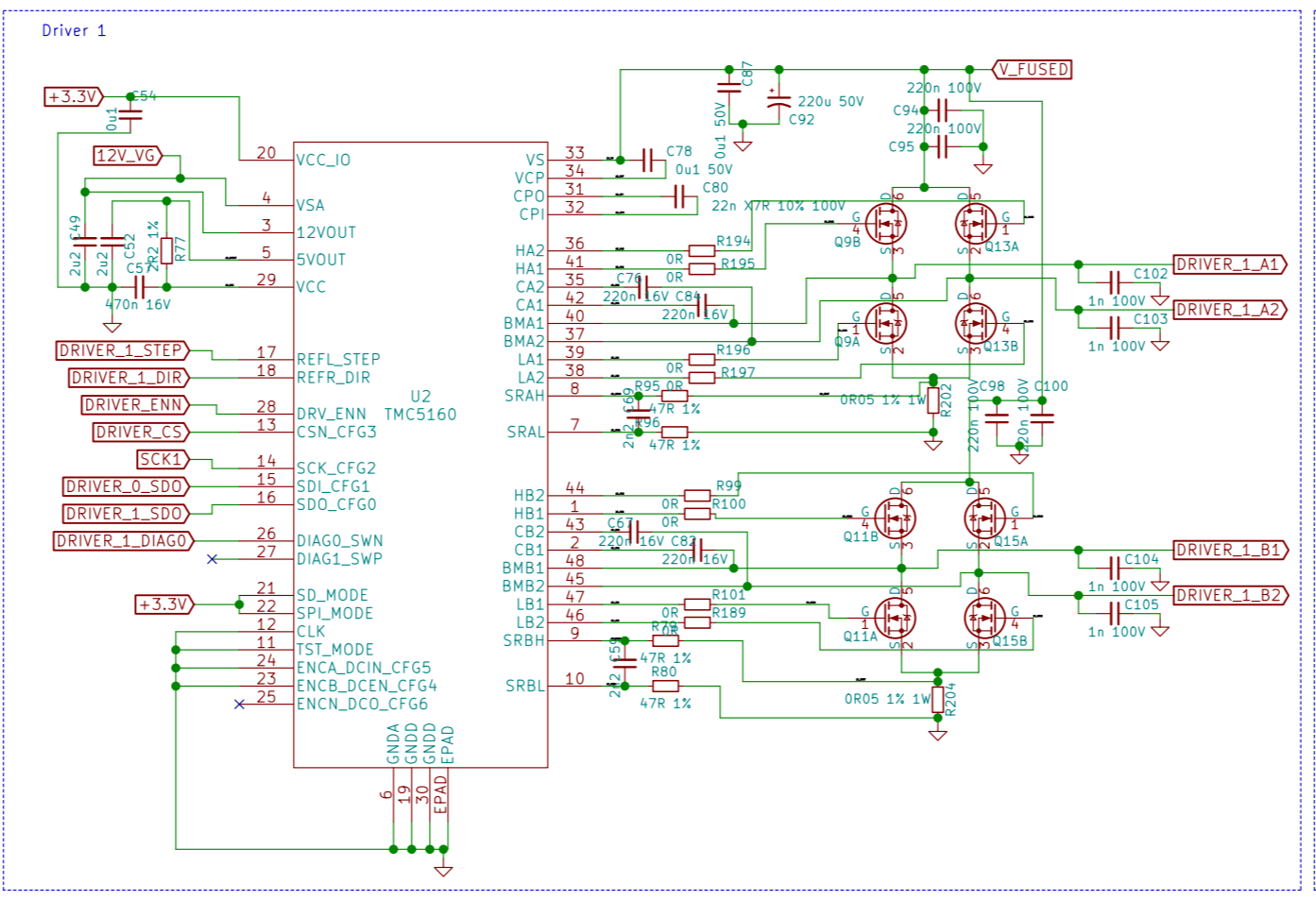
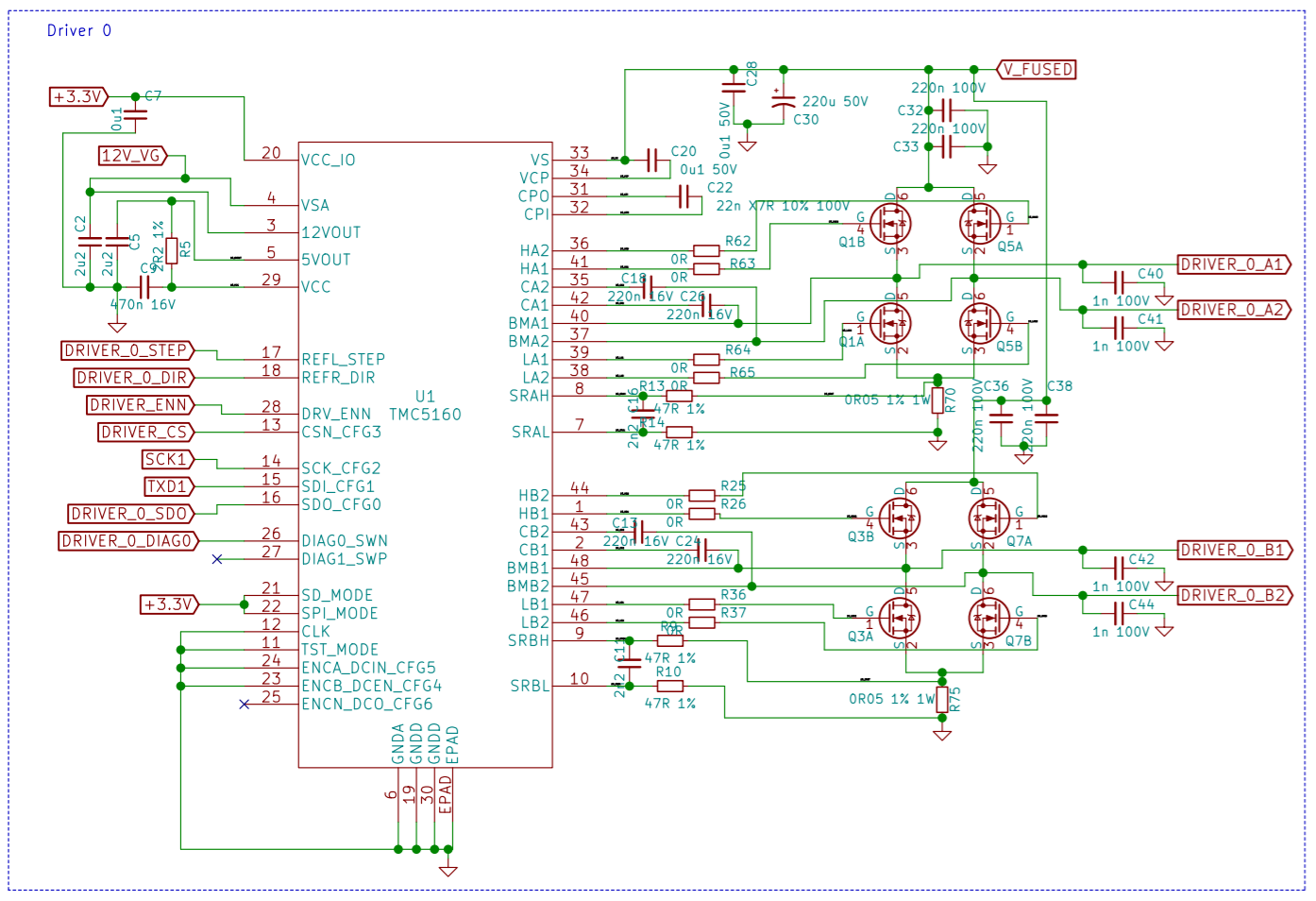

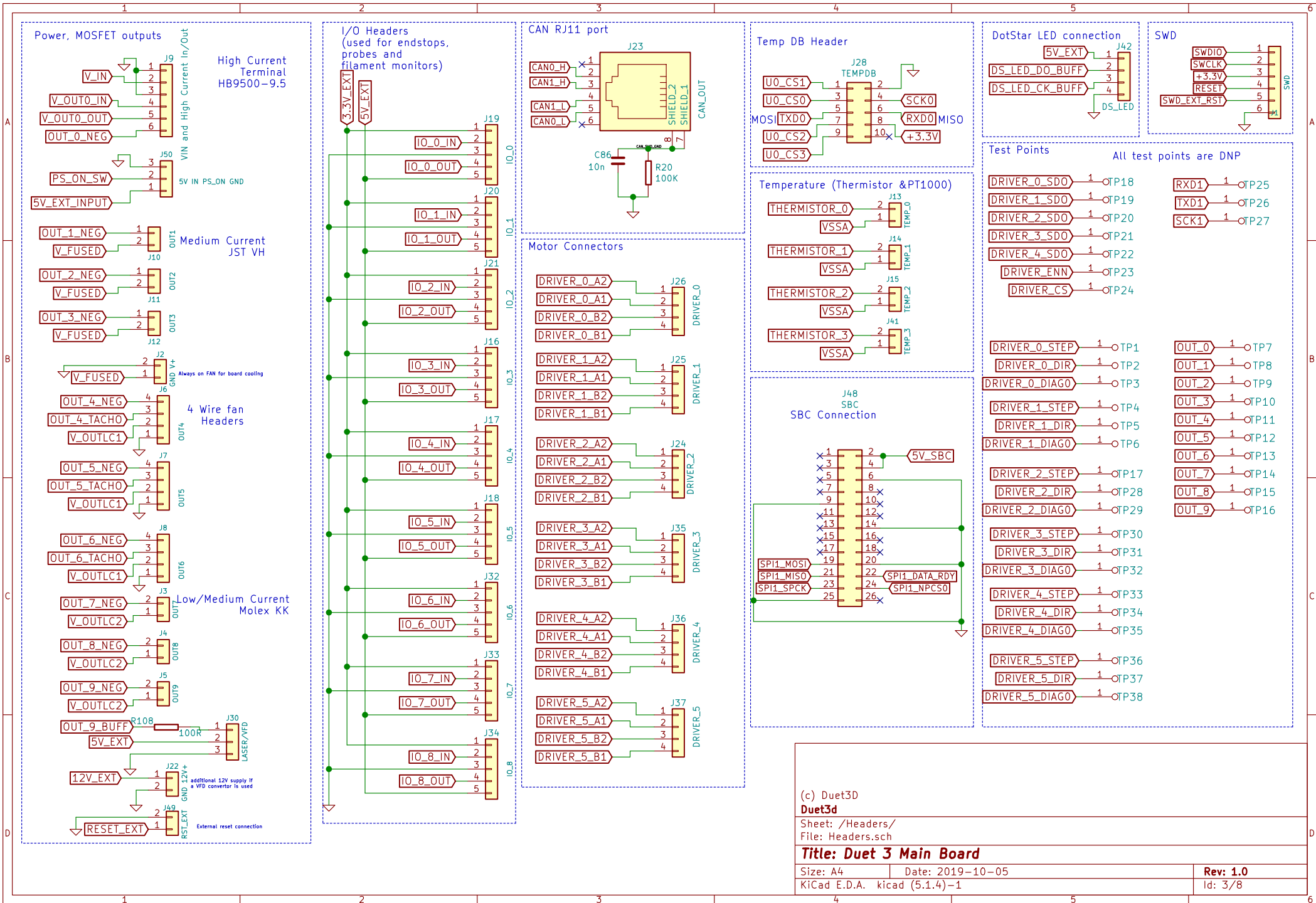

(c) Duet3D  
Duet3d

Sheet: /Headers/  
File: Headers.sch

**Title: Duet 3 Main Board**

Size: A4 Date: 2019-10-05  
KiCad E.D.A. kicad (5.1.4)-1

Rev: 1.0  
Id: 3/8





OUT0 - OUT3 - High current MOSFETs

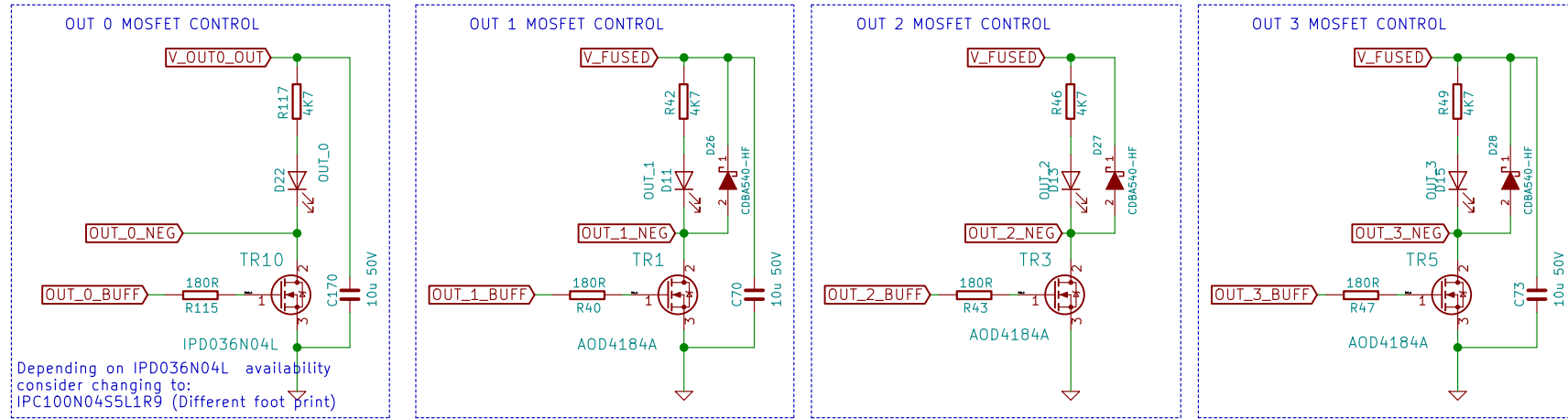

Depending on IPD036N04L availability consider changing to: IPC100N04S5L1R9 (Different foot print)

2 10u caps should be fine for the three medium power FETs

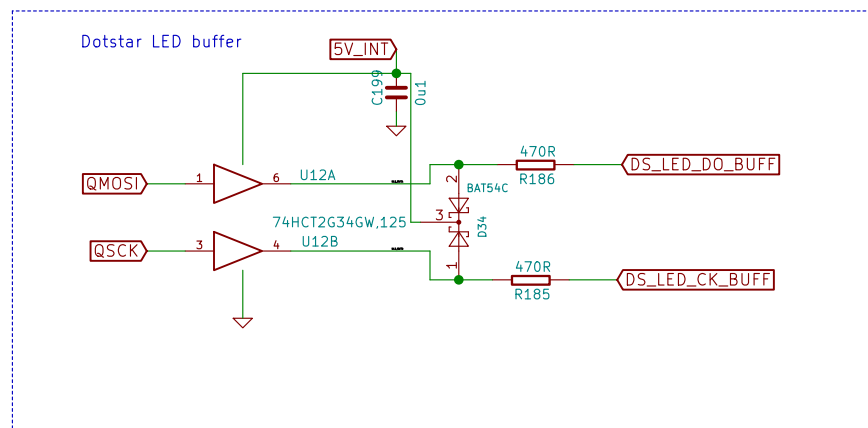
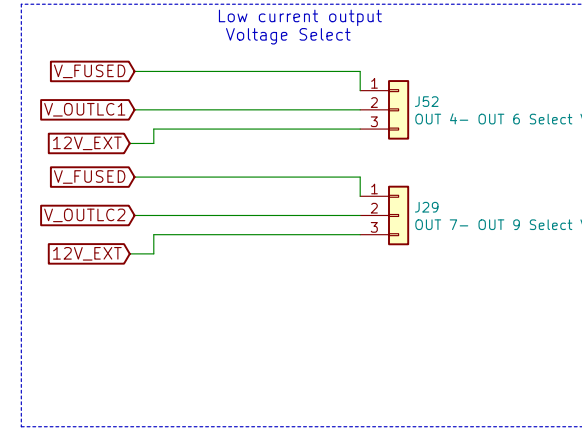
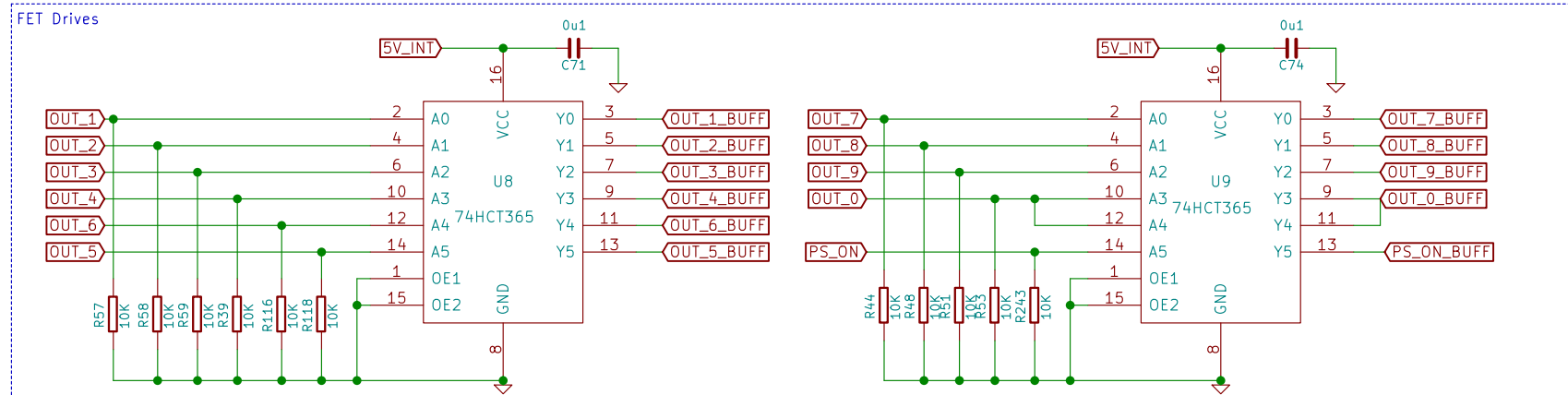
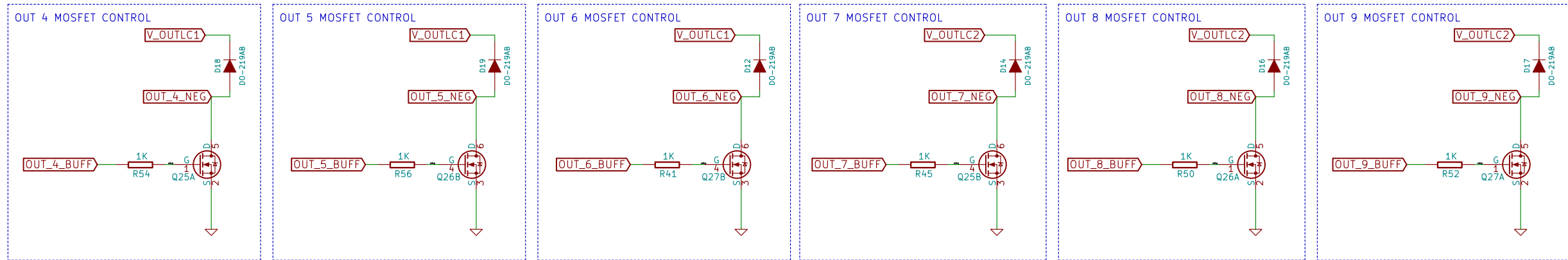



IO inputs (Used for endstops, probes, filament monitors and other low speed IO)

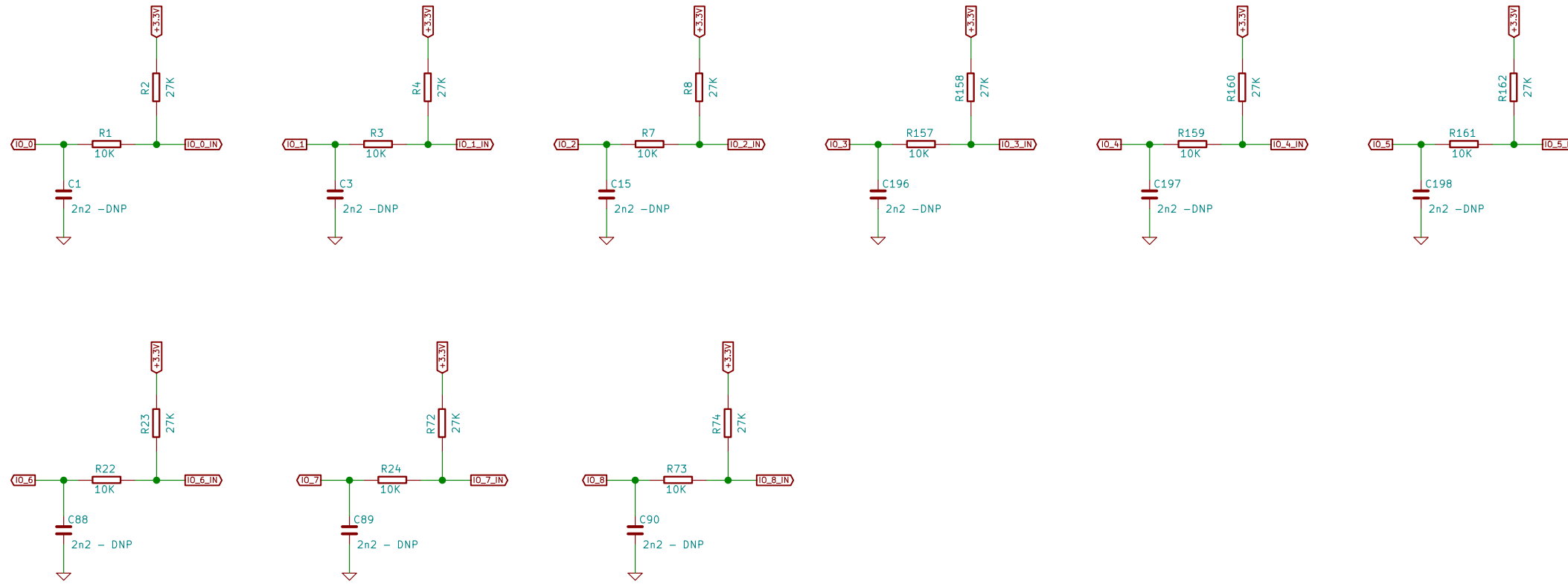

Input Protection

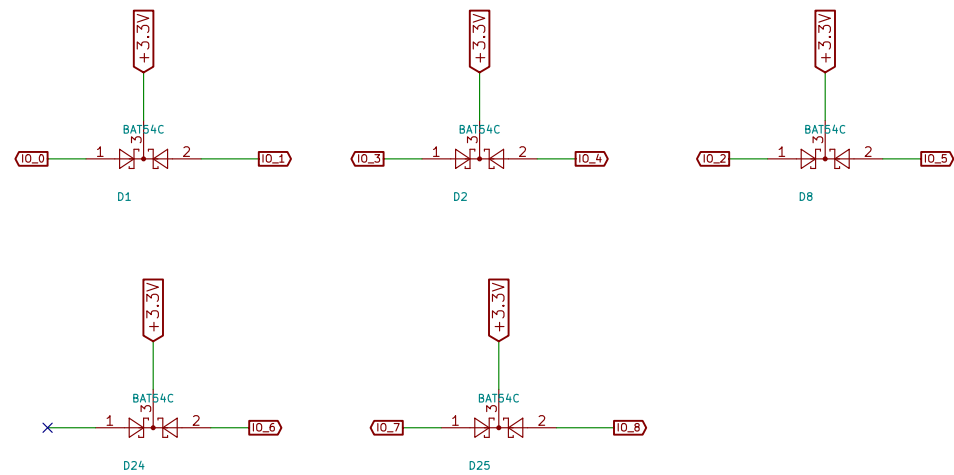

(c) Duet3D

Duet3D

Sheet: /sheet5F4EC370/

File: Endstops.sch

**Title: Duet 3 Main Board**

Size: A3 Date: 2019-10-05

Rev: 1.0

KiCad E.D.A. kicad (5.1.4)-1

Id: 8/8